

LTR Series

Turbine flow meters
with built-in loading
valve

To 800 lpm, 480 bar



The LTR range of turbine flow meters with built-in loading valves, provide a complete solution to the flow measurement of hydraulic systems on test stands, machine tools and other fixed or mobile applications. The flow meter can be installed anywhere in the hydraulic circuit for production testing, commissioning, development testing and control systems. The compact design allows the LTR series flow meters to be installed where space is limited.

The integral loading valve provides smooth progressive pressure control in both flow directions allowing components such as cylinders or motors to be tested without re-plumbing the test connections.

A wide range of readouts and signal converters are available which provide the instrumentation needed to analyse the performance of pumps, motors, valves and hydrostatic transmissions.

Features

- **FLOW:** 10 - 800 lpm
- **PRESSURE:** Up to 480 bar (7000 psi)
- **ACCURACY:** $\pm 1\%$ of indicated reading over a wide range (depending on readout)
- **LOADING VALVE:** with **bi-directional** flow and pressure loading capability*
- **'INTERPASS'TM** safety disc system, bypasses oil internally in the event of the valve being over pressurised
- **TEMPERATURE:** sensor built-in
- **FLUIDS:** Wide range of hydraulic, lubrication oil, and fuels
- **CALIBRATION:** 21 cSt as standard. Special calibration possible

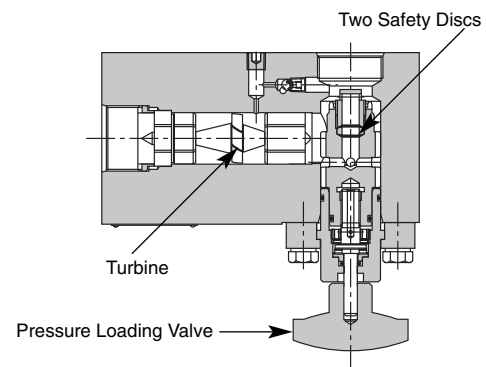

*Greater flow reading accuracy is obtained in the forward direction.

Another quality product from the Webster Range

Specifications

Model Number	Accuracy & flow range when used with a Webster linearised readout						K factor (nominal pulses)	Max. cont. Pressure
	Bottom range		Mid range		Top range			
	lpm	Accuracy	lpm	Accuracy	lpm	Accuracy	Per litre	bar
LT250R	10 - 20	± 0.30 lpm	20 - 250	1% IR	250 - 300	1% IR	135	420
LT400R	10 - 20	± 0.50 lpm	20 - 400	1% IR	N/A	N/A	135	420
LT750R	20 - 40	± 0.40 lpm	40 - 750	1% IR	750 - 800	1% IR	57	210
LT750HPR	20 - 25	± 0.40 lpm	40 - 750	1% IR	750 - 800	1% IR	57	480

Measurement and indication

Flow

Measured by the electronic count of an axial turbine that is designed to minimise the effects of variations in temperature and viscosity. A magnetic transducer monitors the speed of the turbine. Built-in flow straighteners reduce flow turbulence and allow flow measurement in both directions. To measure flows over 800 lpm see LTU bulletin for more details.

Accuracy

All Webster flow meters have excellent repeatability giving accuracy of better than ±1% of the full-scale reading when used over their full flow range and within the viscosity band 10 - 30 cSt. Improved accuracy can be attained through special calibration for different viscosities and with frequency-flow linearisation that is offered with most Webster readouts. Depending on the readout used accuracy of 1% of the indicated reading can be obtained as shown in the table above. Please contact sales to discuss your application.

Construction

Flow block

High tensile aluminium block houses a six-blade turbine rotating on a stainless steel bearing and shaft. The flow straighteners and turbine design minimise the effects of turbulence and swirl, allowing the flowmeter to be connected with 90-degree bends on the inlet and outlet ports. The flowmeter block has 1/4" BSPF ports for pressure or temperature sensors. Optional loading valves, readouts and signal converters are available.

Loading valve

The unique design of the pressure-balanced poppet ensures low handle effort throughout the flow and pressure ranges in addition to excellent tactile feedback, regardless of flow direction. In the event of overpressure, replaceable safety

Duty cycle

LTR series flow meters can be run continuously within the bottom and mid flow ranges and intermittently in the top range. The 'HP' models have designed for heavy-duty applications with piston pumps, continuous pressure spikes or system pressures up to 480 bar.

Temperature

Sensed by a thermistor housed in the transducer for fast response and simplified cable connection.

Resistance 30,000 ohms at 30 °C

Accuracy ± 1 °C over range 0 - 90 °C

Consult sales office for linear output temperature sensors.

discs (situated within the poppet) rupture, to internally by-pass the oil at low pressure. Safety discs with different pressure ranges up to 480 bar are available. Consult sales office for further information.

Transducer

The self energised magnetic reluctance transducer has an output voltage of 80 mV RMS at minimum flow. The transducer output frequency is proportional to flow rate and is typically 20 - 1500 Hertz. Resistance 4300 ohms.

Seals

Viton seals compatible with oil, fuels, water glycol and water oil emulsions. EPDM seals for use with phosphate-ester are available. Consult sales office.

Installation

LTR turbines have built-in flow straighteners so the normal recommended length of 10Ø of straight tube can be reduced to 8 Ø where space is limited. 90-degree bends are permitted on the loading valve end of the block, but should always be of a similar bore size to that of the flowmeter to prevent venturi or constriction effects. The Webster range of flow meters can be used for intermittent or continuous testing of flow in either direction. Standard transducer output connection is 5 pin DIN. Cannon MS type connectors are available. Consult sales office for details.

Connection Details

Pin No.	Function
1 & 2	Transducer
3 & 4	Thermistor
5	Ground

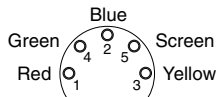

View from Solder Side

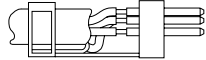

Solder screen and link wire to cable clamp as shown FT7884

Pressure Drop Chart

Hydraulic Oil Viscosity 28 Centistokes

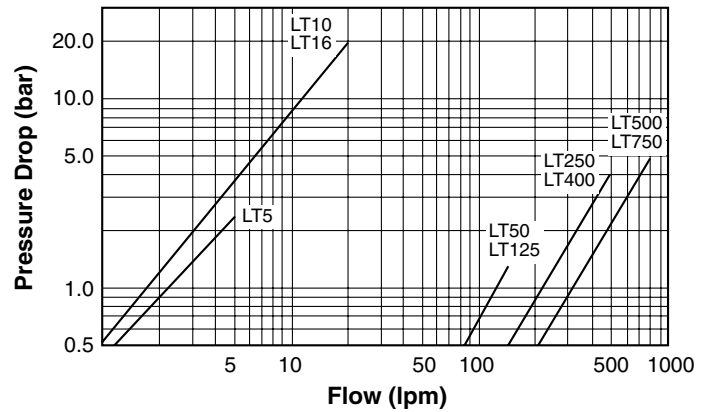

Note

1 UK gallon = 4.546092 litres
1 US gallon = 3.785412 litres

LTR (Dimensions in Millimetres)

Model No	Port Size	A	B	C	D	E	F	G
LT250R	1" BSPF*	51	98	171	222	-	-	-
LT400R	1" BSPF*	51	98	171	222	-	-	-
LT750R	1 1/2" Flange	76	117	184	254	1/2" UNC	70	36
LT750HPR	1 7/8" UNF	76	117	216	235	-	-	-

* UNF ports available

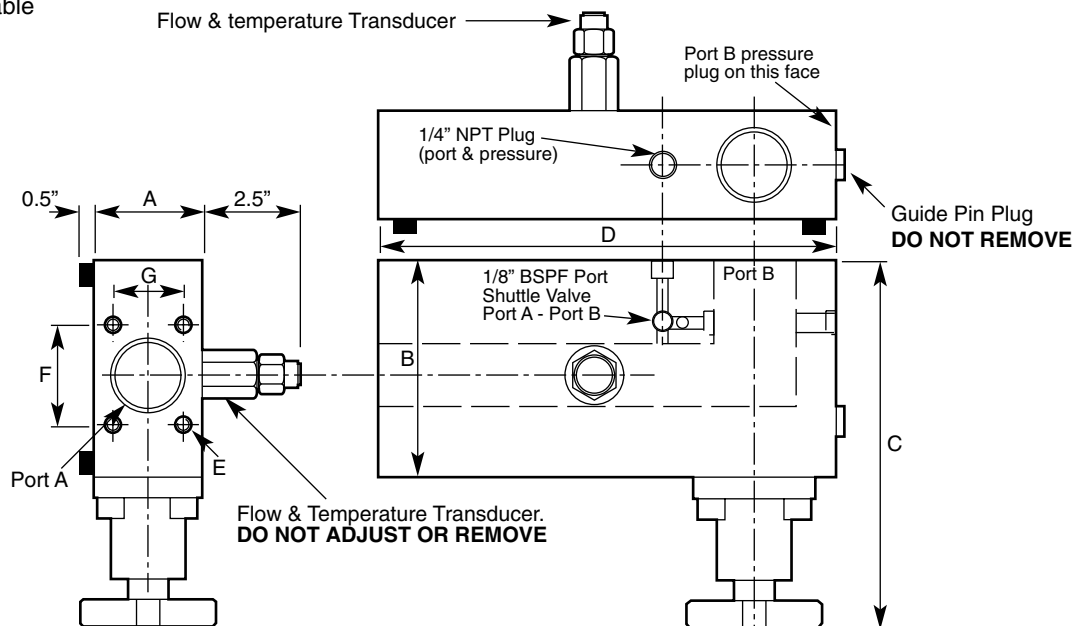

See LT Bulletin

LT (Dimensions in Millimetres)

Model No	Port Size	A	B	C	D	E	F	G	H UNC	J	K	L UNC	M	N	P	Q	R
LT50	3/4" BSPF*	64	191	51	50	102	105	45	1/4"	-	-	-	101	9.5	31.8	105	-
LT125	3/4" BSPF*	64	191	51	50	102	105	45	1/4"	-	-	-	101	9.5	31.8	105	-
LT250	1" BSPF*	64	191	51	50	102	105	45	1/4"	-	-	-	101	9.5	33.3	105	-
LT400	1" BSPF*	64	191	51	50	102	105	45	1/4"	-	-	-	101	9.5	33.3	105	-
LT500	1 1/2" SAE Flange	102	213	76	50	127	111	70	3/8"	35.7	69.8	1/2"	127	16	31.8	143	38
LT750	1 1/2" SAE Flange	102	213	76	50	127	111	70	3/8"	35.7	69.8	1/2"	127	19	31.8	143	38
LT750HP	1 7/8" UNF	102	213	76	50	127	111	70	3/8"	-	-	-	127	19	31.8	143	-

*UNF ports available

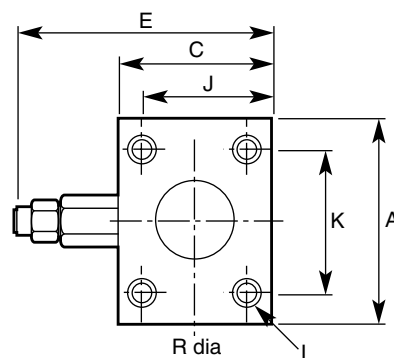
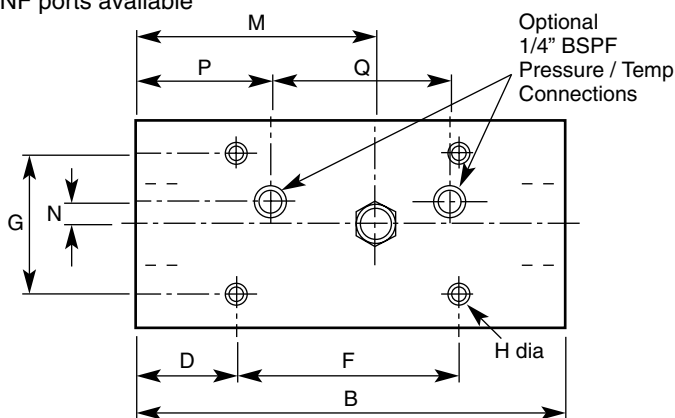

See LTE Bulletin

LTE (Dimensions in Millimetres)

Model No	Port Size*	A	B	C	D	E	F	G	H
LTE15	3/8" BSPF	42	136	50.8	102	68	42	42	23
LTE30	3/4" BSPF	51	165	46 AF	101	79.4	44.5	35.5	28.5
LTE50	3/4" BSPF	51	165	46 AF	101	79.4	44.5	35.5	28.5
LTE125	3/4" BSPF	51	165	46 AF	101	79.4	44.5	35.5	28.5
LTE250	1" BSPF	59.5	165	52.4 AF	108	79.8	44.5	35.5	28.5
LTE400	1" BSPF	59.5	165	52.4 AF	108	79.8	44.5	35.5	28.5

*UNF ports available

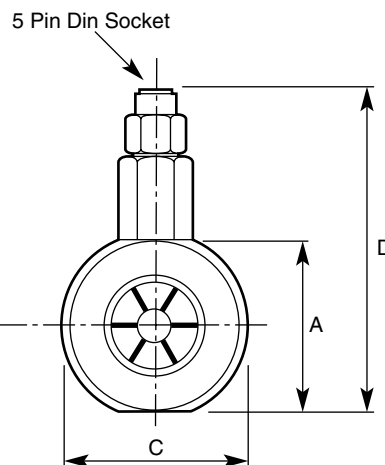
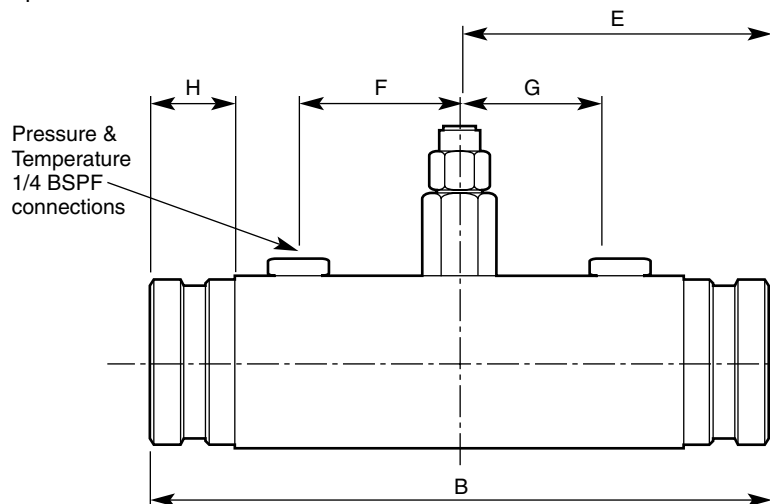

Certificate No.8242

LTE Series

Turbine Flowmeters

To 400 lpm, 420 bar



The LTE range of turbine flowmeters provides a complete solution to the flow measurement of hydraulic systems on test stands, machine tools and other fixed or mobile applications. The flowmeter can be installed anywhere in the hydraulic circuit for production testing, commissioning, development testing and control systems. The compact design allows the LTE series flowmeters to be installed where space is limited.

A wide range of readouts and signal converters are available which provide the instrumentation needed to analyse the performance of pumps, motors, valves and hydrostatic transmissions.

Features

- **FLOW:** 1.0 - 400 lpm
- **PRESSURE:** Up to 420 bar (6000 psi)
- **ACCURACY:** $\pm 1\%$ of indicated reading over a wide range (depending on readout)
- **BI-DIRECTIONAL:** operation
- **TEMPERATURE:** sensor built-in
- **FLUIDS:** Wide range of hydraulic, lubrication oil, and fuels
- **CALIBRATION:** 21 cSt as standard. Special calibration possible

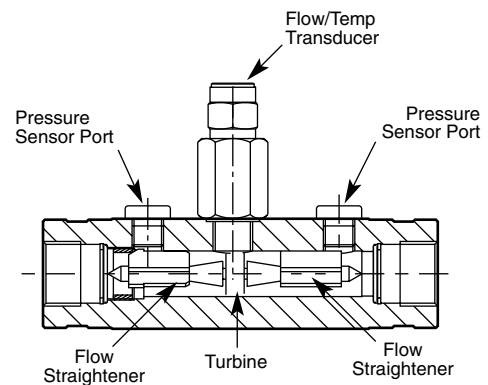

*Greater flow reading accuracy is obtained in the forward direction.

Another quality product from the Webster Range

Specifications

Model Number	Accuracy & flow range when used with a Webster linearised readout						K factor (nominal pulses)	Max. cont. Pressure
	Bottom range		Mid range		Top range			
	lpm	Accuracy	lpm	Accuracy	lpm	Accuracy	Per litre	bar
LTE15	1 - 5	± 0.1 lpm	5 - 15	1% IR	15 - 25	1% IR	6000	420
LTE30	1 - 5	± 0.1 lpm	5 - 50	1% IR	50 - 60	1% IR	630	420
LTE50	2 - 10	± 0.1 lpm	10 - 50	1% IR	50 - 60	1% IR	630	420
LTE125	5 - 10	± 0.25 lpm	10 - 125	1% IR	125 - 150	1% IR	630	420
LTE250	10 - 20	± 0.30 lpm	20 - 250	1% IR	250 - 300	1% IR	135	420
LTE400	10 - 20	± 0.50 lpm	20 - 400	1% IR	N/A	N/A	135	420

Measurement and indication

Flow

Measured by the electronic count of an axial turbine that is designed to minimise the effects of variations in temperature and viscosity. A magnetic transducer monitors the speed of the turbine. Built-in flow straighteners reduce flow turbulence and allow flow measurement in both directions. To measure flows over 800 lpm see LTU bulletin for more details.

Accuracy

All Webster flow meters have excellent repeatability giving accuracy of better than ±1% of the full-scale reading when used over their full flow range and within the viscosity band 10 - 30 cSt. Improved accuracy can be attained through special calibration for different viscosities and with frequency-flow linearisation that is offered with most Webster readouts. Depending on the readout used accuracy of 1% of the indicated reading can be obtained as shown in the table above. Please contact sales to discuss your application.

Duty cycle

LT series flow meters can be run continuously within the bottom and mid flow ranges and intermittently in the top range. For heavy duty applications with piston pumps, continuous pressure spikes or system pressures up to 480 bar, please consult the sales office for 'HP' models.

Temperature

Sensed by a thermistor housed in the transducer for fast response and simplified cable connection. Resistance 30,000 ohms at 30°C
Accuracy ± 1°C over range 0 - 90 °C
Consult sales office for linear output temperature sensors.

Construction

Flow block

High tensile aluminium block houses a six blade turbine rotating on a stainless steel bearing and shaft. The flow straighteners and turbine design minimise the effects of turbulence and swirl. The one piece assembly can be easily removed for cleaning. The standard block has a 1/8" BSPF port for a pressure or temperature sensor. Alternatively one or two 1/4" BSPF ports can be provided. Optional loading valves, readouts and signal converters are available.

increased operating range, contact sales office for more details). The transducer output frequency is proportional to flow rate and is typically 20 - 1500 Hertz. Resistance 4300 ohms.

Seals

Viton seals compatible with oil, fuels, water glycol and water oil emulsions. EPDM seals for use with phosphate-ester are available. Consult sales office.

Transducer

The self energised magnetic reluctance transducer has an output voltage of 80 mV RMS at minimum flow (the LTE30 uses a powered transducer for

Installation

LTE turbines have built-in flow straighteners so the normal recommended length of 10Ø of straight tube can be reduced to 8Ø where space is limited. Inlet and outlet connections can be 90 degree bends but should always be of an adequate size to prevent venturi or constriction effects. The Webster range of flow meters can be used for intermittent or continuous testing of flow in either direction. Standard transducer output connection is 5 pin DIN. Cannon MS type connectors are available. Consult sales office for details.

Connection Details

Pin No.	Function
1 & 2	Transducer
3 & 4	Thermistor
5	Ground

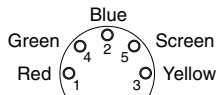

View from Solder Side

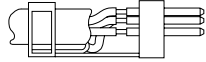

Solder screen and link wire to cable clamp as shown
FT7884

Pressure Drop Chart

Hydraulic Oil Viscosity 28 Centistokes

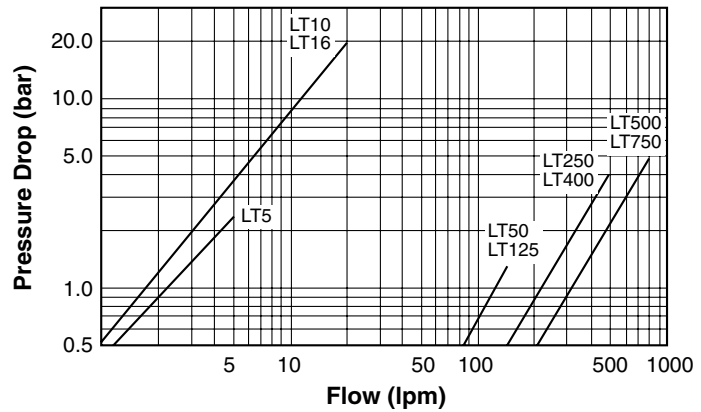

Note

1 UK gallon = 4.546092 litres
1 US gallon = 3.785412 litres

LTE (Dimensions in Millimetres)

Model No	Port Size*	A	B	C	D	E	F	G	H
LTE15	3/8" BSPF	42	136	50.8	102	68	42	42	23
LTE30	3/4" BSPF	51	165	46 AF	101	79.4	44.5	35.5	28.5
LTE50	3/4" BSPF	51	165	46 AF	101	79.4	44.5	35.5	28.5
LTE125	3/4" BSPF	51	165	46 AF	101	79.4	44.5	35.5	28.5
LTE250	1" BSPF	59.5	165	52.4 AF	108	79.8	44.5	35.5	28.5
LTE400	1" BSPF	59.5	165	52.4 AF	108	79.8	44.5	35.5	28.5

*UNF ports available

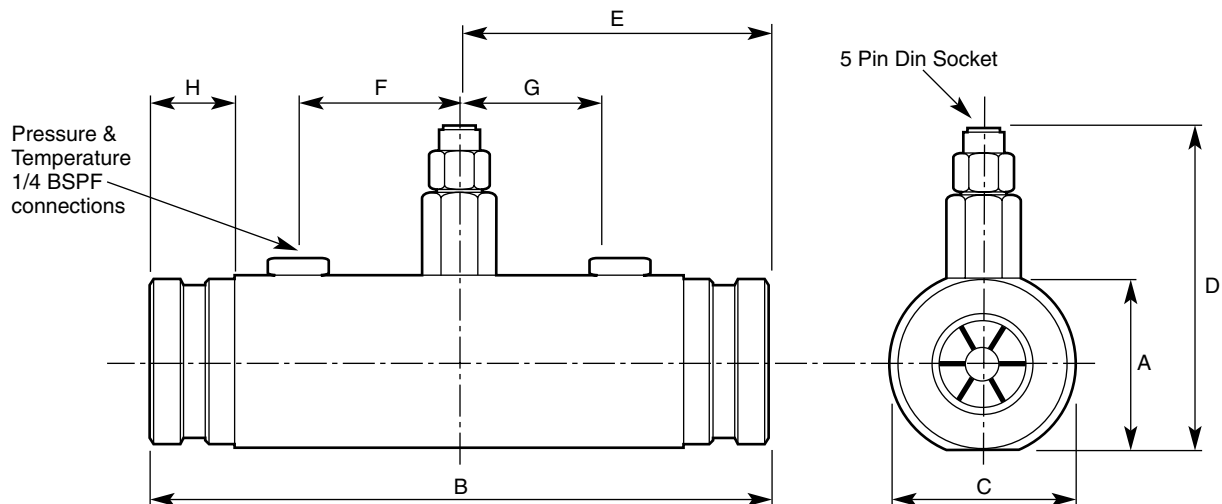

See LT Bulletin

LT (Dimensions in Millimetres)

Model No	Port Size	A	B	C	D	E	F	G	H UNC	J	K	L UNC	M	N	P	Q	R
LT50	3/4" BSPF*	64	191	51	50	102	105	45	1/4"	-	-	-	101	9.5	31.8	105	-
LT125	3/4" BSPF*	64	191	51	50	102	105	45	1/4"	-	-	-	101	9.5	31.8	105	-
LT250	1" BSPF*	64	191	51	50	102	105	45	1/4"	-	-	-	101	9.5	33.3	105	-
LT400	1" BSPF*	64	191	51	50	102	105	45	1/4"	-	-	-	101	9.5	33.3	105	-
LT500	1 1/2" SAE Flange	102	213	76	50	127	111	70	3/8"	35.7	69.8	1/2"	127	16	31.8	143	38
LT750	1 1/2" SAE Flange	102	213	76	50	127	111	70	3/8"	35.7	69.8	1/2"	127	19	31.8	143	38
LT750HP	1 7/8" UNF	102	213	76	50	127	111	70	3/8"	-	-	-	127	19	31.8	143	-

*UNF ports available

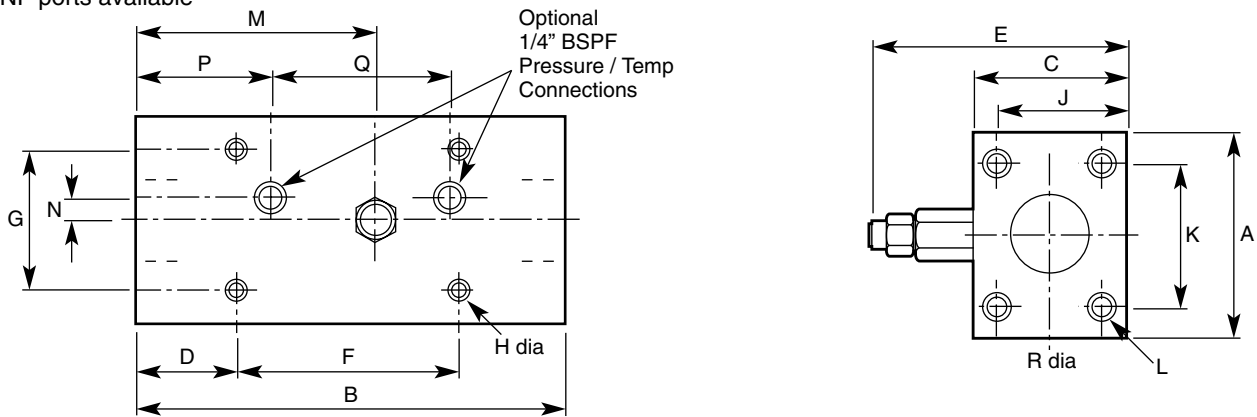

See LTR Bulletin

LTR (Dimensions in Millimetres)

Model No	Port Size	A	B	C	D	E	F	G
LT250R	1" BSPF*	51	98	171	222	-	-	-
LT400R	1" BSPF*	51	98	171	222	-	-	-
LT750R	1 1/2" Flange	76	117	184	254	1/2" UNC	70	36
LT750HPR	1 7/8" UNF	76	117	216	235	-	-	-

* UNF ports available

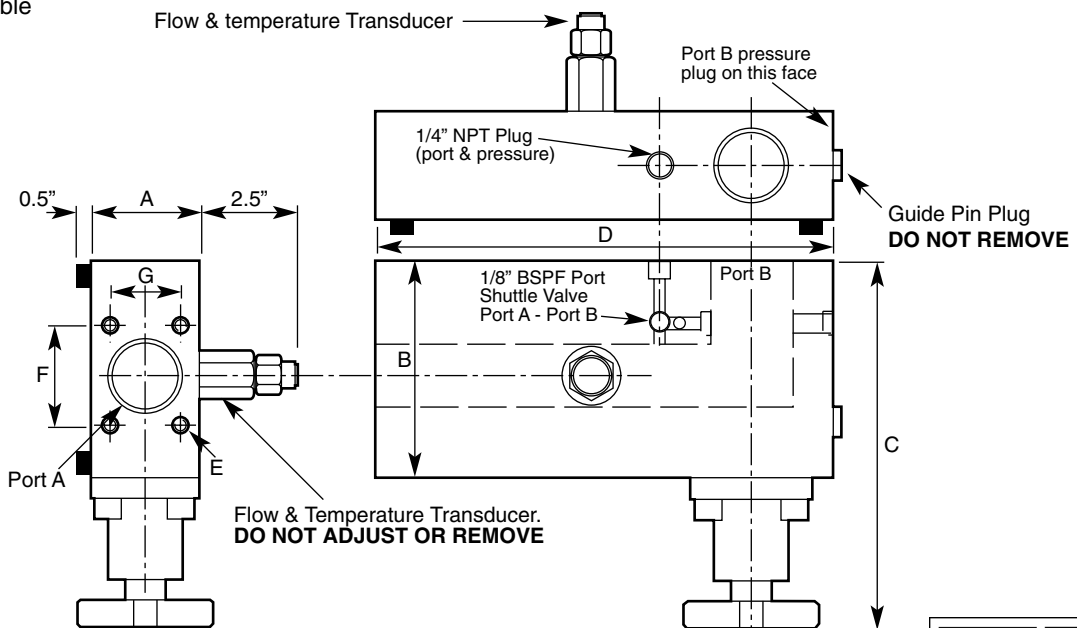

Certificate No.8242